



| ROMI C 420 | ROMI C 510 | ROMI C 620 | ROMI C 680 | ROMI C 830 | ROMI C 1000 | ROMI C 1000BB

CNC LATHES

ROMI C SERIES





ROMI Industrial Complex, in
Santa Bárbara d'Oeste - SP, Brazil

INNOVATION + QUALITY

ROMI: Since 1930 producing high technology.

Since its foundation, the company is recognized by its focus on creating products and innovative solutions which guarantees its technological leadership among big manufacturers of machine tools market. ROMI industrial complex is among the most modern and productive ones in the segments of machine tools, plastic processing machines and cast iron parts of high quality.

Continuous investments in Research & Development result in products with state-of-the-art technology.

The high technology applied to Romi machines offer highly reliable products, with high accuracy, efficiency and great flexibility for several types of machining processes.

Romi R&D is focused on increasing competitiveness for its customers.

Present throughout Brazil and in over 60 countries.

Romi covers all domestic territory through its sales subsidiaries network fully prepared to support customers supplying an extensive range of services from marketing to after sales.

International market is covered by its subsidiaries located in United States, Mexico and Europe and also by its dealers network located in strategic logistic centers around the globe completely capable for serving customers in 5 continents.



Plant 16

ROMI C SERIES



| ROMI C 420 | ROMI C 510 | ROMI C 620 | ROMI C 680 | ROMI C 830 | ROMI C 1000 | ROMI C 1000BB

Flexibility and high productivity.

CNC Lathes from ROMI C Series are machines with great versatility for machining different types of parts, with great levels of power, quick movements and machining accuracy.

With robust structure, high rigidity and stability, it provides a great performance in the most varied conditions of machining.

Flexibility and productivity for several types of machining processes.



- Headstock ASA A2-5" - 4,000 rpm
- Main motor: 12.5 cv / 9.0 kW
- Manual positioning tailstock with manual drive quill
- CNC Siemens Sinumerik 828D with high performance and reliability

- Headstock ASA A2-6" - 3,000 rpm or
- Headstock ASA A2-8" - 2,200 rpm
- Main motor : 15 hp / 11 kW
- Manual positioning tailstock with manual drive quill
- CNC Siemens Sinumerik 828D with high performance and reliability

ROMI C 420 / C 510

Capacities

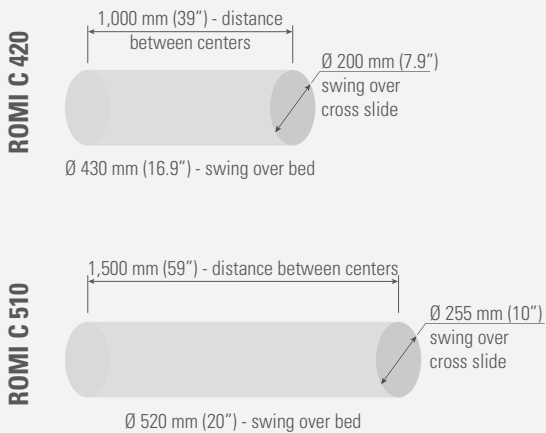

Power Graphs

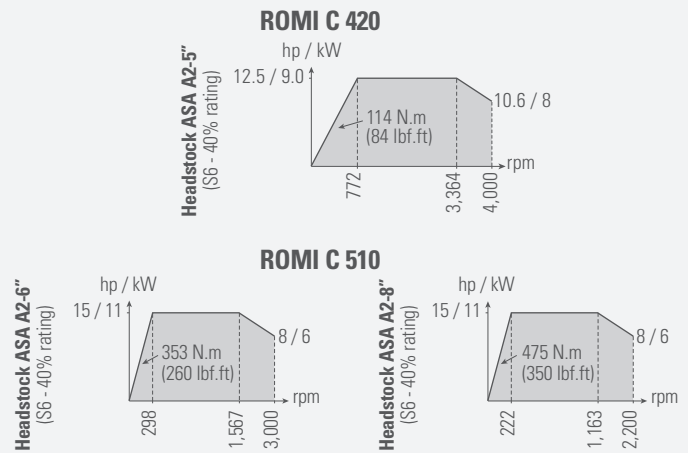

Drawings are not in scale.

Power and flexibility for parts machining with chuck and middle size shafts



- Headstock ASA A2-8" - 1,800 rpm
- Main motor: 25 hp / 18.5 kW
- Tailstock positioning system by drag device with saddle and manual drive quill
- CNC Siemens Sinumerik 828D with high performance and reliability

- Geared headstock with two speed ranges: 450 rpm (range 1) and 1,800 rpm (range 2) - ASA A2-8"
- Main motor: 45 hp / 33.6 kW
- Tailstock positioning system by drag device with saddle and manual drive quill
- CNC Siemens Sinumerik 828D with high performance and reliability

ROMI C 620 / ROMI C 680

Capacities

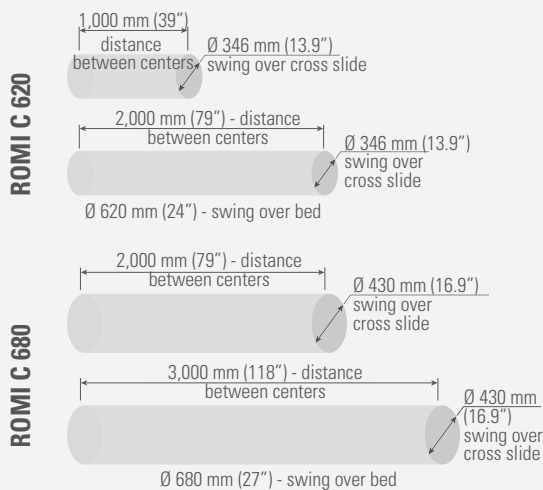

Power Graphs

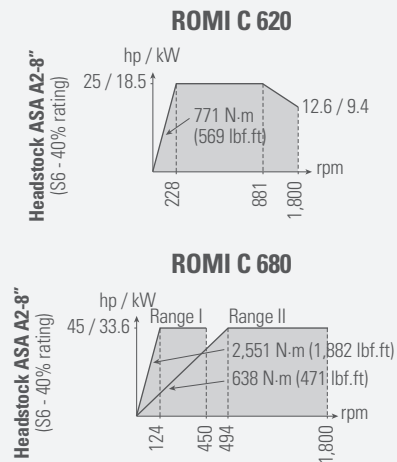

Drawings are not in scale.

Robust and powerful heavy machining with efficiency and productivity.



- Geared headstock with two speed ranges: 250 rpm (range 1) and 1,000 rpm (range 2) - ASA A2-11"
- Geared headstock with two speed ranges: 200 rpm (range 1) and 550 rpm (range 2) - ASA A2-15"
- Main motor: 45 hp / 33.6 kW
- Tailstock positioning system by drag device with saddle and manual drive quill (built-in)
- CNC Siemens Sinumerik 828D with high performance and reliability

- Geared headstock with two speed ranges: 125 rpm (range 1) and 500 rpm (range 2) - ASA A2-20"
- Main motor: 45 hp / 33.6 kW
- Tailstock positioning system by drag device with saddle and manual drive quill (built-in)
- CNC Siemens Sinumerik 828D with high performance and reliability



ROMI C 830 / ROMI C 1000

Capacities

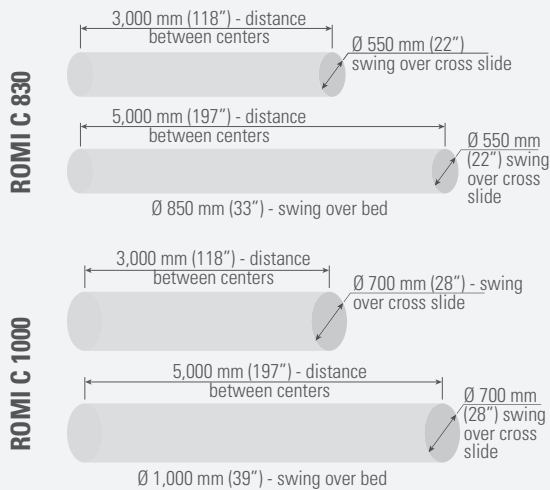

Power Graphs

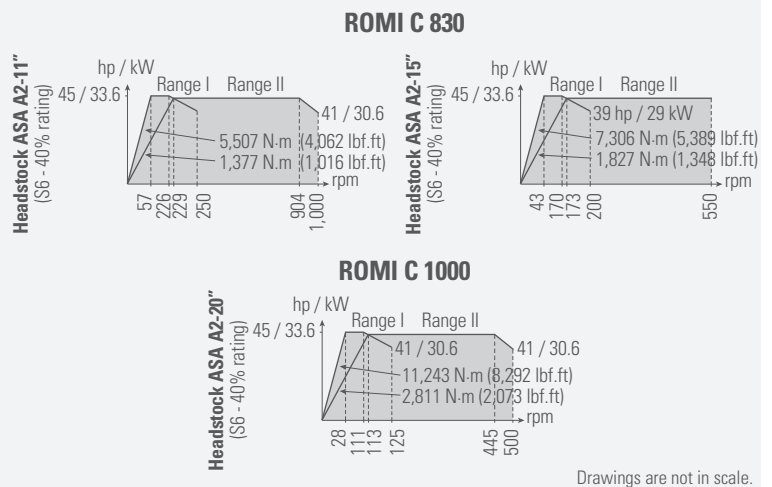

High rigidity and stability for machining operations at full power.



- Geared headstock with two speed ranges: 125 rpm (range 1) and 400 rpm (range 2) ASA A2-20"
- Main motor: 45 hp / 33.6 kW
- Tailstock positioning system by drag device with saddle and manual drive quill (built-in)
- CNC Siemens Sinumerik 828D with high performance and reliability

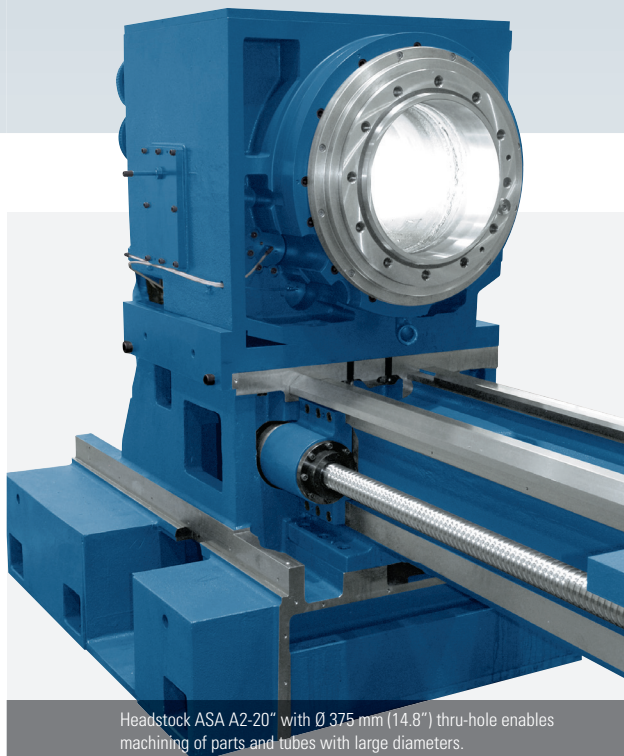

Headstock ASA A2-20" with $\varnothing 375$ mm (14.8") thru-hole enables machining of parts and tubes with large diameters.

ROMI C 1000BB (Big Bore)

Capacities

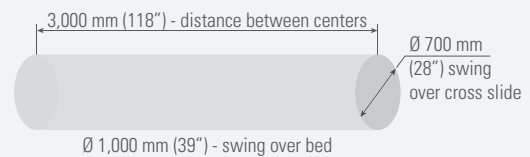

Power Graphs

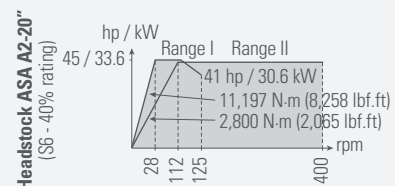

Drawings are not in scale.

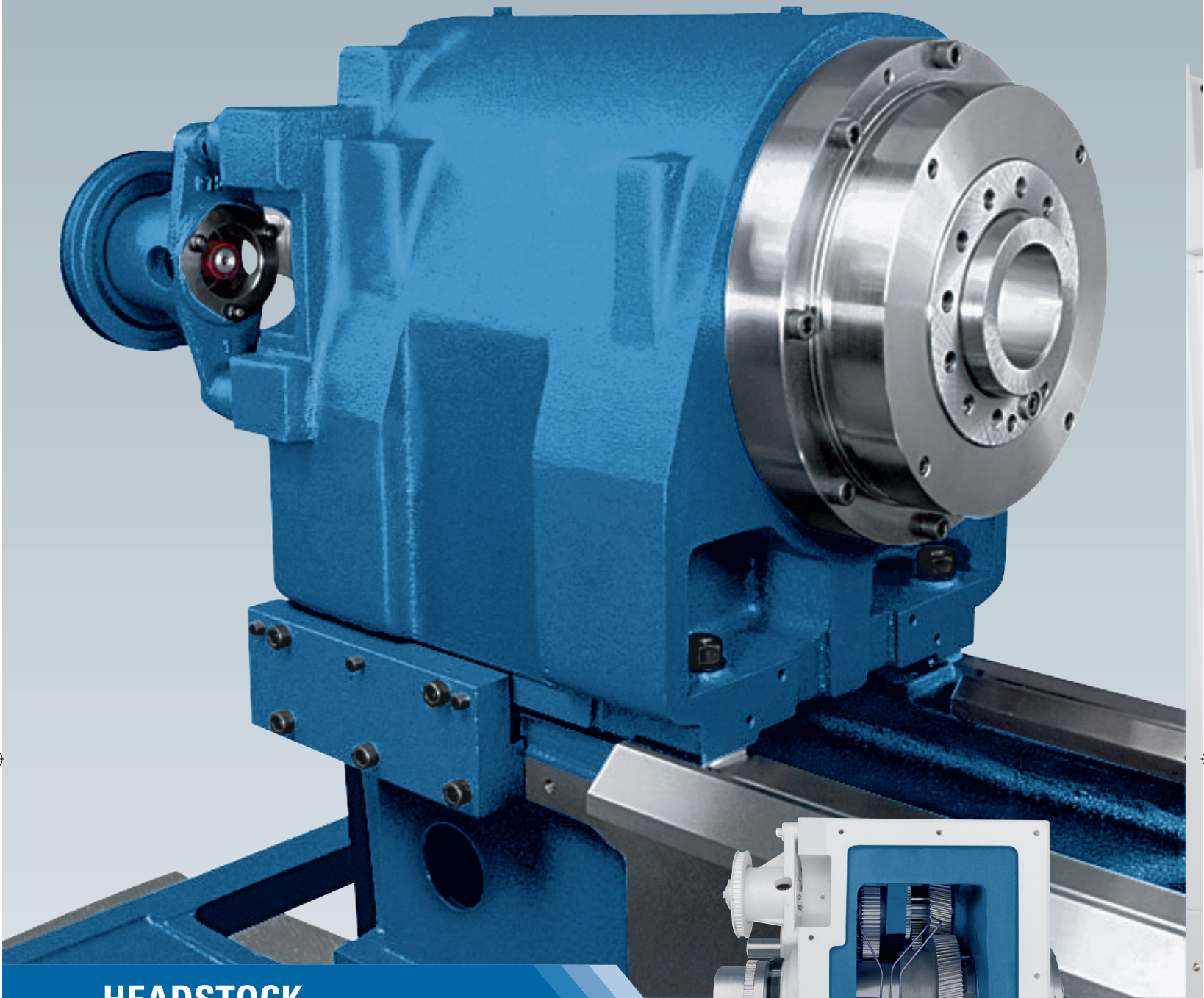

HEADSTOCK

Headstock **ROMI C 420, C 510 and C 620**

Robust framework that incorporates the cartridge. They have spindle supported by precision bearings with high load capacity offering rigidity and great vibration absorption under severe cutting conditions, allowing machining workpieces with excellent geometric accuracy. They are driven by AC motor through pulleys and micro-V belt, which delivers high torque and continuously variable speed.

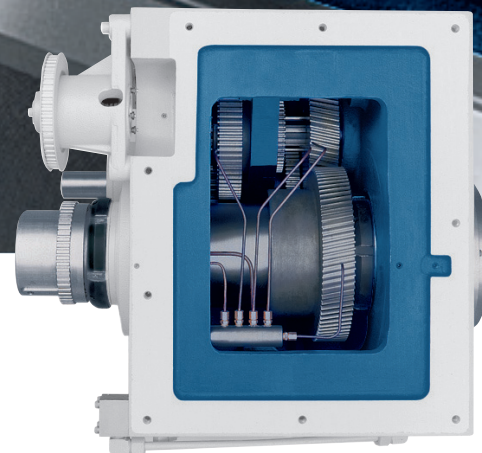

Geared Headstock **ROMI C 680, C 830, C 1000 and C 1000BB**

They have gears and shafts hardened, ground, dynamically balanced, designed to withstand high efforts of the most severe working conditions. Headstock components are lubricated by oil recirculating system, which ensures constant and efficient lubrication for high performance and long durability.



CHUCKS

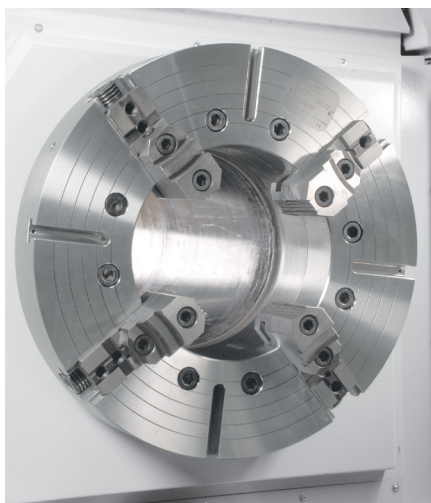

Chucks

CNC lathes from ROMI C SERIES can be configured with several types of chuck (*):

- 3-jaw universal chuck
- 3-jaw pneumatic chuck
- 3-jaw hydraulic chuck
- 4-jaw independent chuck
- 4-jaw independent rear chuck (ROMI C 830, C 1000 and C 1000BB)

(*): mandatory choice optionals with availability according to machine model.

Rear chuck (optional)

ROMI C 830, C 1000 and C 1000BB can be equipped with 4-jaw independent rear chuck:

- Ø 550 mm (22") (ASA A2-11")
- Ø 700 mm (28") (ASA A2-11")
- Ø 720 mm (28") (ASA A2-20")

It is an important accessory for holding long shafts and tubes. Machines have an access door for jaws opening and closing.



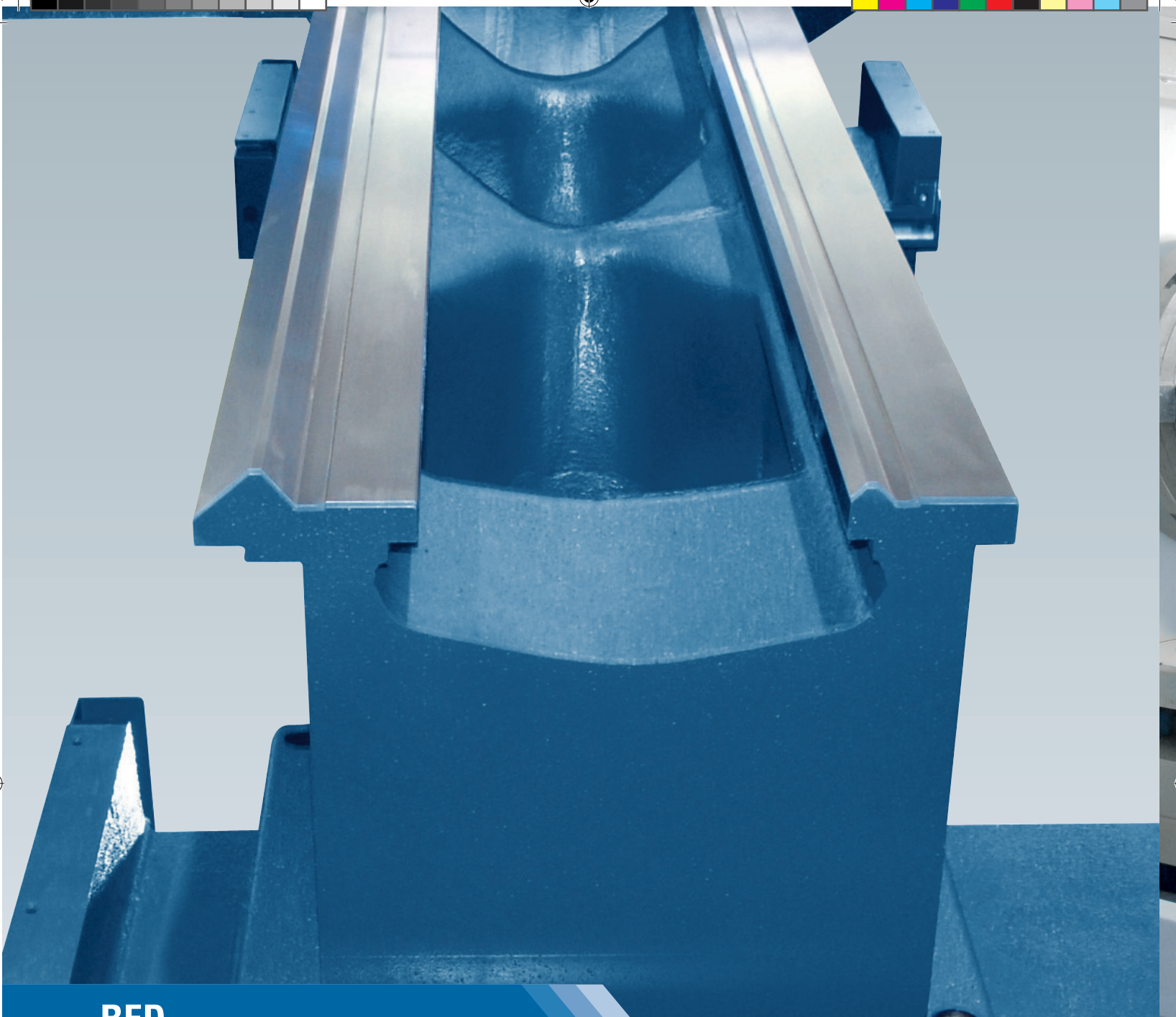

BED

CNC lathes from ROMI C SERIES have bed with robust structure supported by cast iron columns, internally ribbed to absorb vibrations during several types of machining conditions.

Flat and prismatic guides are hardened and ground to ensure high wear resistance. They constitute a self-adjusting system assuring permanent contact of cross slide over the bed.

These features offers high rigidity, stability and precision in machining operations at full power.

Saddle and cross slide

Guides are hardened and ground.

Guideways are covered with a low friction coefficient material, to enable excellent performance in displacements and accelerations.

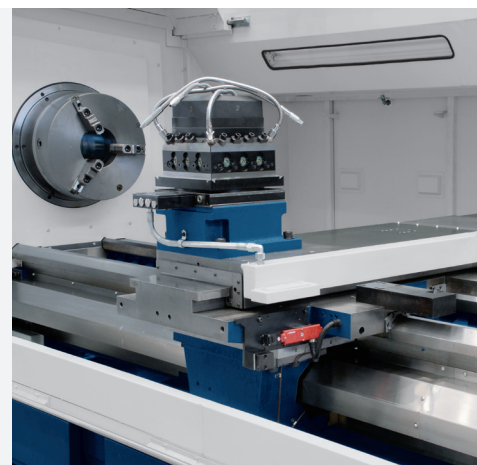



4-position electrical turret - vertical

TOOL HOLDERS

Tool holders and turrets (optionals)

- Quick change tool holder
- Rear tool holder
- Gang tools
- 8-position square turret - indexing
- 4-position square turret - manual
- 4-position turret - vertical
- 8-position turret - horizontal
- 8-position turret - horizontal for driven tool



Quick change tool holder (optional)



Gang tools (optional)

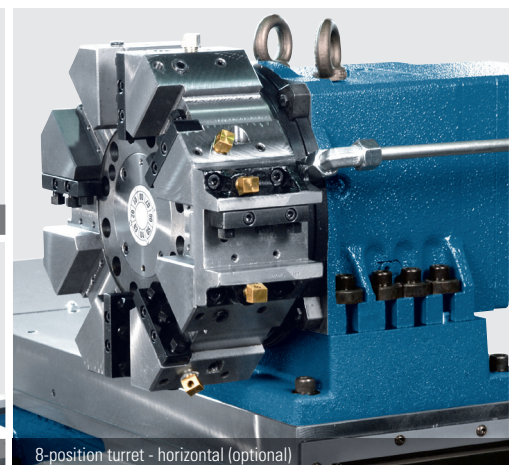

8-position turret - horizontal (optional)

U-type steady rest.
(ROMI C 620 / C 680 / C 830 / C 1000 / C 1000BB)



STEADY RESTS

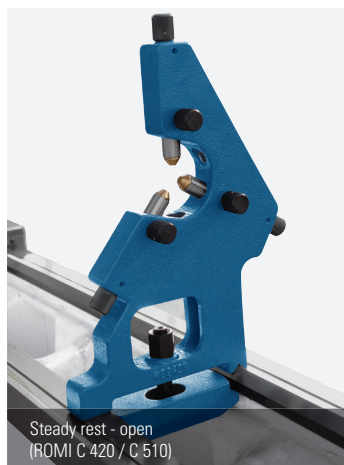

Steady rest - open
(ROMI C 420 / C 510)



Steady rest - closed
(ROMI C 420 / C 510 / C 620 / C 680)



Follow rest
(ROMI C 420 / C 510)

In order to hold long parts (such as shafts, tubes) the CNC lathes from ROMI C SERIES can be equipped with different types of rests (optionals) offering a perfect support for workpieces.



TAILSTOCK

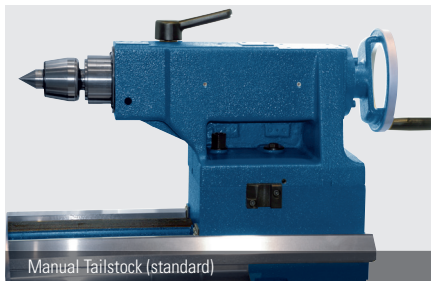

Manual Tailstock (standard)

ROMI C SERIES lathes are equipped with tailstock with manual drive quill (standard).



Pneumatic Tailstock (optional ROMI C 420)



Hydraulic Tailstock (optional)

ROMI C 830 and C 1000 are equipped with manual drive quill tailstock built-in (incorporated bearings) MT-5 live center, offering high load capacity, high rigidity and vibration absorption.

Tailstock positioning system by drag device with saddle.

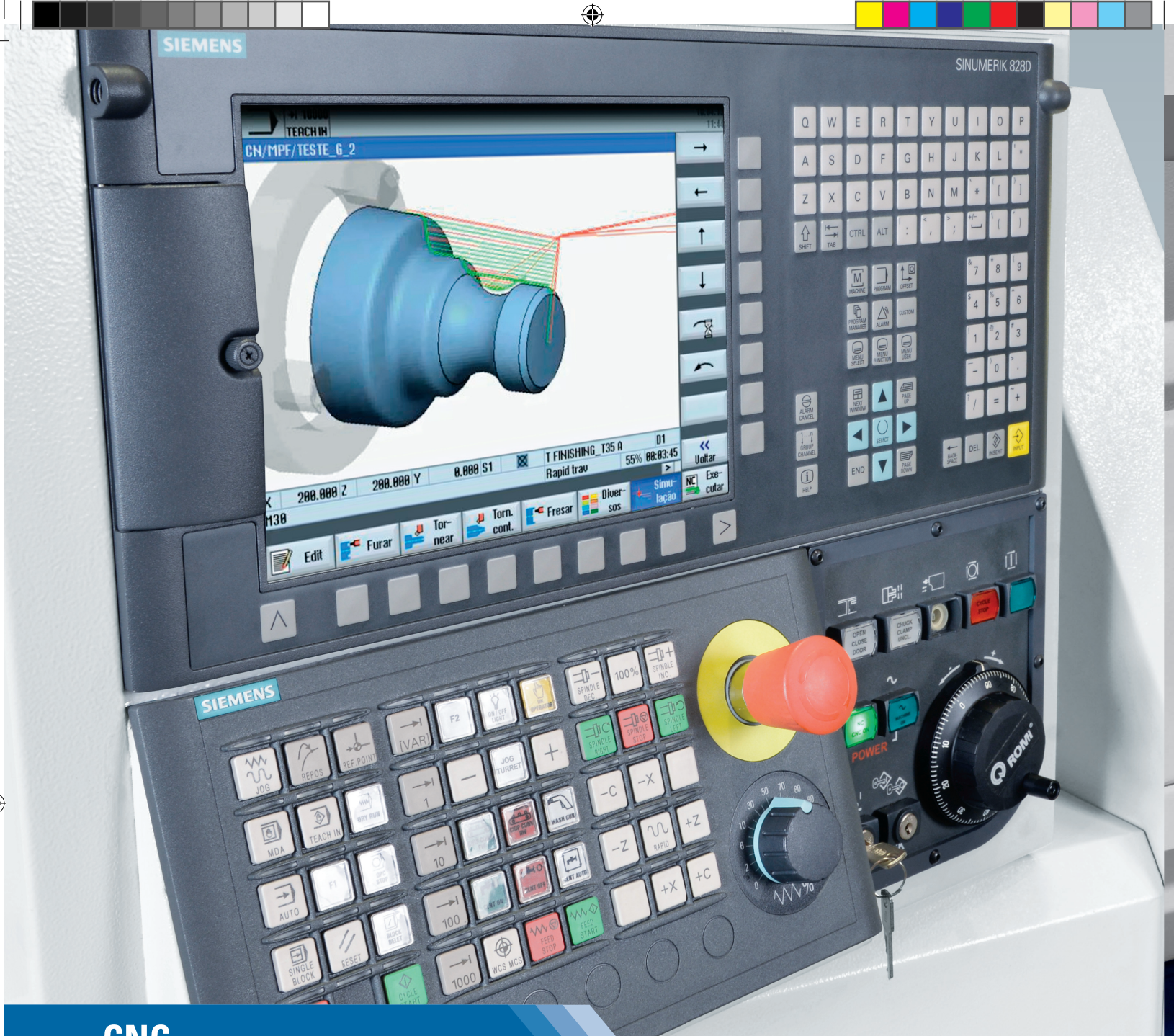

CNC

Technology, performance and reliability

CNC Siemens Sinumerik 828D

10.4" LCD color monitor with softkeys for functions selection and activation, Portuguese language screen, communication interfaces: USB port, drive for Compact Flash card and Ethernet interface (optional), providing the user the flexibility for loading programs and parameters.

It offers excellent resources for creating and editing machining programs, such as canned cycles for turning and drilling, linear and circular interpolation functions, thread opening

functions, reference functions, coordinate systems, 256 pairs of tool wear offsets, tool life cycle manager, 3 Mbytes of memory, background editing and excellent resources for simulation of 2D machining. Besides, the conversation system Program Guide is also available which that allows creation of machining programs in an easy and quick manner, through graphical resources, without the need of ISO codes.

Carriage with electronic handwheels which enables the movement of X and Z axis for machining parts as in an engine lathe. (ROMI C 420 / C 510 / C 620)



RMMP



Control panel with electronic handwheels.
(ROMI C 680 / C 830 / C 1000 / C 1000BB)

It enables machine operation in manual mode thru electronic handwheels and also in auto mode (joystick and cycle start).

Operator can machine parts like in an engine lathe with electronic handwheels and control panel joystick.

He can also fill the fields in CNC screen, informing speed, feeds, cut depth, coordinates and angles, and execute the machining by pressing the cycle start key.



Technical specifications		ROMI C 420	ROMI C 510	ROMI C 620	ROMI C 680
Capacity					
Centers height	mm (in)	215 (8.5)	260 (10.2)	310 (12.2)	352 (13.9)
Distance between centers	m (in)	1.0 (39)	1.5 (59)	1.0 / 2.0 (39 / 79)	2.0 / 3.0 (79 / 118)
Swing over bed	mm (in)	430 (16.9)	520 (20)	620 (24)	680 (27)
Swing over cross slide	mm (in)	200 (7.9)	255 (10)	346 (13.6)	430 (16.9)
Swing over saddle wings	mm (in)	400 (15.7)	450 (17.7)	540 (21)	620 (24)
Cross slide travel (X axis)	mm (in)	220 (8.7)	280 (11)	360 (14.2)	360 (14.2)
Longitudinal carriage travel (Z axis)	mm (in)	1,065 (42)	1,555 (61)	1,025 / 2,025 (40 / 80)	2,025 / 3,025 (80 / 119)
Bed					
Width	mm (in)	305 (12)	340 (13.4)	380 (15)	380 (15)
Height	mm (in)	350 (13.8)	336 (13.2)	400 (15.7)	400 (15.7)
Headstock					
Spindle nose	ASA	A2-5"	A2-6"	A2-8"	A2-8"
Spindle hole diameter	mm (in)	53 (2.1)	65 (2.6)	80 (3.1)	104 (4.1)
Transmission system		Direct drive	Direct drive	Direct drive	Geared
Speed ranges	rpm	4 to 4,000	3 to 3,000	2 to 2,200	1 to 1,800
	Range I				1 to 452
	Range II				1 to 1,800
Feeds					
Rapid traverse (Z axis)	m/min (in/min)	10 (394)	10 (394)	8 (315)	8 (315)
Rapid traverse (X axis)	m/min (in/min)	10 (394)	10 (394)	8 (315)	8 (315)
Manual Tailstock					
Body positioning		Manual	Manual (std) / Drag through the table (opt)	Manual (std) / Drag through the table (opt)	Drag trough the table
Quill drive		Manual (std) / Pneumatic or Hydraulic (opt)	Manual (std) / Pneumatic or Hydraulic (opt)	Manual (std) / Hydraulic (opt)	Manual (std) / Hydraulic (opt)
Maximum quill stroke	mm (in)	120 (4.7)	130 (5.1)	180 (7.1)	180 (7.1)
Quill diameter	mm (in)	60 (2.4)	80 (3.1)	100 (3.9)	130 (5.1)
Quill taper hole	CM	4	4	5	5
Installed power					
AC Main motor (S6 - 40% rating)	hp / kW	12.5 / 9	15 / 11	25 / 18.5	45 / 33.6
AC Main motor (continuous rating)	kVA	15	20	25	50
Dimensions and weight (*)					
Floor space required - 1.0 m between centers	m (in)	3.10 x 1.24 (122 x 49)	-	3.85 x 2.08 (152 x 82)	-
Floor space required - 1.5 m between centers	m (in)	-	3.75 x 1.68 (148 x 66)	-	-
Floor space required - 2.0 m between centers	m (in)	-	-	4.85 x 2.08 (191 x 82)	6.65 x 2.43 (262 x 96)
Floor space required - 3.0 m between centers	m (in)	-	-	-	7.70 x 2.43 (303 x 96)
Floor space required - 5.0 m between centers	m (in)	-	-	-	-
Approx. net weight - 1.0 m between centers	kg (lbs)	2,500 (5,500)	-	5,000 (11,000)	-
Approx. net weight - 1.5 m between centers	kg (lbs)	-	3,750 (8,200)	-	-
Approx. net weight - 2.0 m between centers	kg (lbs)	-	-	5,550 (12,200)	6,300 (13,900)
Approx. net weight - 3.0 m between centers	kg (lbs)	-	-	-	7,000 (15,400)
Approx. net weight - 5.0 m between centers	kg (lbs)	-	-	-	-

(*) Without chip conveyor





Technical specifications		ROMI C 830		ROMI C 1000	ROMI C 1000BB (Big Bore)
Capacity					
Centers height	mm (in)	435 (17.1)		510 (20)	510 (20)
Distance between centers	m (in)	3.0 / 5.0 (118 / 197)		3.0 / 5.0 (118 / 197)	3.0 (118)
Swing over bed	mm (in)	850 (33)		1,000 (39)	1,000 (39)
Swing over cross slide	mm (in)	550 (22)		700 (28)	700 (28)
Cross slide travel (X axis)	mm (in)	520 (20)		520 (20)	520 (20)
Longitudinal carriage travel (Z axis)	mm (in)	3,020 / 5,020 (119 / 198)		3,020 (119)	3,020 (119)
Bed					
Width	mm (in)	460 (18.1)		460 (18.1)	460 (18.1)
Height	mm (in)	420 (16.5)		420 (16.5)	420 (16.5)
Headstock					
Spindle nose	ASA	A2-11"	A2-15"	A2-20"	A2-20"
Spindle hole diameter	mm (in)	160 (6.3)	260 (10.2)	320 (12.6)	375 (14.8)
Transmission system		Geared		Geared	Geared
Speed ranges	rpm	1 to 1,000	1 to 550	1 to 500	1 to 400
	Range I	1 to 250	1 to 194	1 to 126	1 to 125
	Range II	1 to 1,000	1 to 550	1 to 500	1 to 400
Feeds					
Rapid traverse (Z axis)	m/min (in/min)	8 (315) (*) / 5 (197) (**)		8 (315) (*) / 5 (197) (**)	8 (315)
Rapid traverse (X axis)	m/min (in/min)	8 (315)		8 (315)	8 (315)
Manual Tailstock					
Body positioning		Drag trough the table		Drag trough the table	Drag trough the table
Quill drive		Manual (std) / Hydraulic (opt)		Manual (std) / Hydraulic (opt)	Manual (std) / Hydraulic (opt)
Maximum quill stroke	mm (in)	200 (7.9)		200 (7.9)	200 (7.9)
Quill diameter	mm (in)	130 (5.1)		130 (5.1)	130 (5.1)
Quill taper hole	CM	5		5	5
Installed power					
AC Main motor (S6 - 40% rating)	hp / kW	45 / 33.6		45 / 33.6	45 / 33.6
Total installed power	kVA	50		50	50
Dimensions and weight (***)					
Floor space required - 1.0 m between centers	m (in)	-		-	-
Floor space required - 1.5 m between centers	m (in)	-		-	-
Floor space required - 2.0 m between centers	m (in)	-		-	-
Floor space required - 3.0 m between centers	m (in)	7.52 x 3.20 (296 x 126)		7.52 x 3.20 (296 x 126)	7.52 x 3.20 (296 x 126)
Floor space required - 5.0 m between centers	m (in)	9.52 x 3.20 (375 x 126)		9.52 x 3.20 (375 x 126)	-
Approx. net weight - 1.0 m between centers	kg (lbs)	-		-	-
Approx. net weight - 1.5 m between centers	kg (lbs)	-		-	-
Approx. net weight - 2.0 m between centers	kg (lbs)	-		-	-
Approx. net weight - 3.0 m between centers	kg (lbs)	10,250 (22,600)		10,250 (22,600)	11,600 (25,600)
Approx. net weight - 5.0 m between centers	kg (lbs)	13,750 (30,300)		13,750 (30,300)	-

(*) for 3.0 m between centers

(**) for 5.0 m between centers

(***) Without chip conveyor



Technical specifications			ROMI C 420	ROMI C 510	ROMI C 620	ROMI C 680
Tool holders and turrets						
Quick change tool holder (opt)						
Holders			2 or 3	3	3	3
Tool holder size	Square	mm (in)	20 x 20 (0.79 x 0.79)	25 x 25 (0.98 x 0.98)	32 x 32 (1.26 x 1.26)	32 x 32 (1.26 x 1.26)
	Round	mm (in)	Ø 25 (0.98)	Ø 25 (0.98)	Ø 32 (1.26)	Ø 32 (1.26)
Rear tool holder (opt)						
Tool holder size	Square	mm (in)	20 x 20 (0.79 x 0.79)	25 x 25 (0.98 x 0.98)	25 x 25 (0.98 x 0.98)	25 x 25 (0.98 x 0.98)
	Round	mm (in)	Ø 25 (0.98)	Ø 32 (1.26)	Ø 40 (1.57)	Ø 40 (1.57)
Gang tools (opt)						
Tool holder size	Square	mm (in)	20 x 20 (0.79 x 0.79)	-	-	-
	Round	mm (in)	Ø 25 (0.98)	-	-	-
WTO tool holder (opt)						
VDI-50 tool holder/ DIN 69880-50 (opt)						
Tool holder size	Square	mm (in)	-	32 x 32 (1.26 x 1.26)	-	-
	Round	mm (in)	-	Ø 40 (1.57)	-	-
Axial driven tool holder		DIN 6499	-	ER-40 (Ø 4 to Ø 26 mm)	-	-
Radial driven tool holder		DIN 6499	-	ER-40 (Ø 4 to Ø 26 mm)	-	-
Driven tool speed range		rpm	-	1 to 1,500 rpm	-	-
8-station manual square turret (opt)						
Tool holder size	Square	mm (in)	25 x 25 (0.98 x 0.98)	-	-	-
	Round	mm (in)	Ø 25 (0.98)	-	-	-
4-station square manual tool holder (opt)						
Number of stations / tools			-	-	-	-
Section of external tool holder		mm (in)	-	-	-	-
Section of internal tool holder		mm (in)	-	-	-	-
4-station vertical automatic turret (opt)						
Number of stations / tools		un	-	-	4	4
Tool holder size	Square	mm (in)	-	-	25 x 25 (0.98 x 0.98)	25 x 25 (0.98 x 0.98)
	Round	mm (in)	-	-	Ø 40 (1.57)	Ø 40 (1.57)
8-station horizontal automatic turret (opt)						
Tool holder fixing type			Romi	Romi	Romi or VDI - 40	Romi or VDI - 40
Number of stations / tools		un	8	8	8	8
Tool holder size	Square	mm (in)	25 x 25 (0.98 x 0.98)	25 x 25 (0.98 x 0.98)	25 x 25 (0.98 x 0.98)	25 x 25 (0.98 x 0.98)
	Round	mm (in)	Ø 25 (0.98)	Ø 32 (1.26)	Ø 40 (1.57)	Ø 40 (1.57)
8-station horizontal automatic turret for driven tools (opt)						
Tool holder fixing type			-	-	VDI - 40	VDI - 40
Number of stations / tools		un	-	-	8	8
Tool holder size	Square	mm (in)	-	-	25 x 25 (0.98 x 0.98)	25 x 25 (0.98 x 0.98)
	Round	mm (in)	-	-	Ø 40 (1.57)	Ø 40 (1.57)
Axial driven tool holder		DIN 6499	-	-	ER - 32 (Ø 3 to Ø 20 mm)	ER - 32 (Ø 3 to Ø 20 mm)
Driven tool speed range		rpm	-	-	4 to 4,000	4 to 4,000

Technical specifications			ROMI C 830	ROMI C 1000	ROMI C 1000BB (Big Bore)
Tool holders and turrets					

Quick change tool holder (opt)					
Holders			3	3	3
Tool holder size	Square	mm (in)	40 x 40 (1.57 x 1.57)	40 x 40 (1.57 x 1.57)	40 x 40 (1.57 x 1.57)
	Round	mm (in)	Ø 50 (2) or Ø 60 (2.4)	Ø 50 (2) or Ø 60 (2.4)	Ø 50 (2) or Ø 60 (2.4)
Rear tool holder (opt)					
Tool holder size	Square	mm (in)	-	-	-
	Round	mm (in)	-	-	-
Gang tools (opt)					
Tool holder size	Square	mm (in)	-	-	-
	Round	mm (in)	-	-	-
WTO tool holder (opt)					
VDI-50 tool holder/ DIN 69880-50 (opt)					
Tool holder size	Square	mm (in)	-	-	-
	Round	mm (in)	-	-	-
Axial driven tool holder		DIN 6499	-	-	-
Radial driven tool holder		DIN 6499	-	-	-
Driven tool speed range		rpm	-	-	-
8-station manual square turret (opt)					
Tool holder size	Square	mm (in)	-	-	-
	Round	mm (in)	-	-	-
4-station square manual tool holder (opt)					
Number of stations / tools			4	4	4
Section of external tool holder		mm (in)	40 x 40 (1.57 x 1.57)	40 x 40 (1.57 x 1.57)	40 x 40 (1.57 x 1.57)
Section of internal tool holder		mm (in)	Ø 60 (2.4)	Ø 60 (2.4)	Ø 60 (2.4)
4-station vertical automatic turret (opt)					
Number of stations / tools			4	4	4
Tool holder size	Square	mm (in)	32 x 32 (1.26 x 1.26)	32 x 32 (1.26 x 1.26)	32 x 32 (1.26 x 1.26)
	Round	mm (in)	Ø 50 / Ø 60 / Ø 80 (2.0 / 2.4 / 3.1)	Ø 50 / Ø 60 / Ø 80 (2.0 / 2.4 / 3.1)	Ø 50 / Ø 60 / Ø 80 (2.0 / 2.4 / 3.1)
8-station horizontal automatic turret (opt)					
Tool holder fixing type			-	-	-
Number of stations / tools			-	-	-
Tool holder size	Square	mm (in)	-	-	-
	Round	mm (in)	-	-	-
8-station horizontal automatic turret for driven tools (opt)					
Tool holder fixing type			VDI - 50	VDI - 50	VDI - 50
Number of stations / tools			8	8	8
Tool holder size	Square	mm (in)	32 x 32 (1.26 x 1.26)	32 x 32 (1.26 x 1.26)	32 x 32 (1.26 x 1.26)
	Round	mm (in)	Ø 40 (1.57)	Ø 40 (1.57)	Ø 40 (1.57)
Axial driven tool holder		DIN 6499	-	-	-
Driven tool speed range		rpm	-	-	-

WORLDWIDE PRESENCE

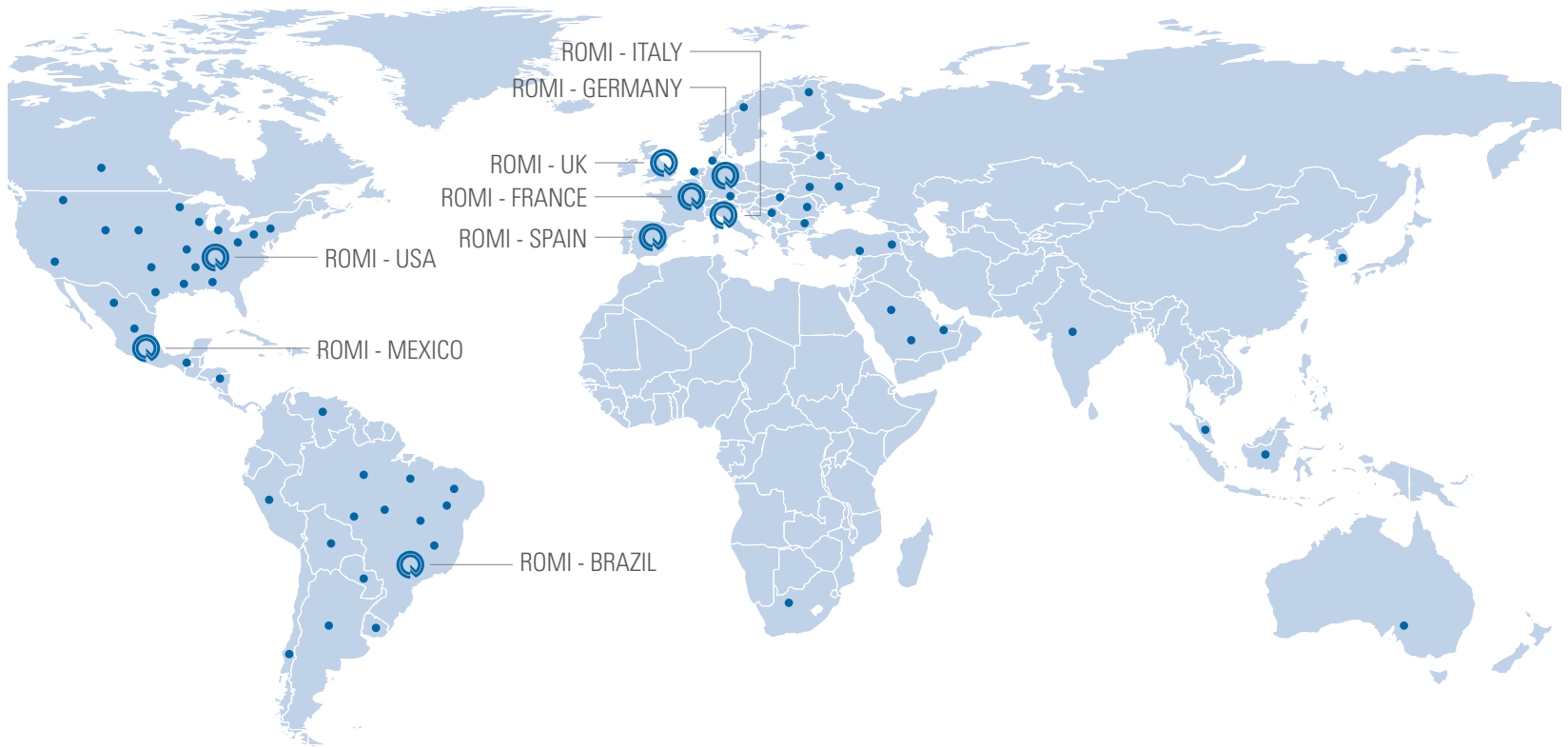

Brazil



United States



Germany



England



France



Spain



Italy



Germany - B+W



ROMI

WWW.ROMI.COM

Indústrias Romi SA
Rod. SP 304, Km 141,5
Santa Bárbara d'Oeste SP
13453 900 Brazil
Phone +55 (19) 3455 9800
Fax +55 (19) 3455 1030
export-mf@romi.com

**Burkhardt+Weber
Fertigungssysteme GmbH**
Burkhardt+Weber-Strasse 57
72760 Reutlingen, Germany
Phone +49 7121 315-0
Fax +49 7121 315-104
info@burkhardt-weber.de
www.burkhardt-weber.de

ROMI Machine Tools, Ltd
1845 Airport Exchange Blvd
Erlanger KY - 41018 USA
Phone +1 (859) 647 7566
Fax +1 (859) 647 9122
sales@romiusa.com

ROMI Europa GmbH
Wasserweg 19 D 64521
Gross Gerau Germany
Phone +49 (6152) 8055 0
Fax +49 (6152) 8055 50
sales@romi-europa.de

ROMI France SAS
Parc de Genève, 240
Rue Ferdinand Perrier 69800
ST Priest
Phone +33 4 37 25 60 70
Fax +33 4 37 25 60 71
infos@romifrance.fr

ROMI Machines UK Limited
Leigh Road
Swift Valley Industrial Estate
Rugby CV21 1DS
Phone +44 1788 544221
Fax +44 1788 542195
sales@romiuk.com

ROMI Máquinas España
Calle Comadrán, 15
Pol. Ind. Can Salvatela
C.P. 08210 - Barberà del Vallès
Phone +34 93 719 4926
Fax +34 93 718 7932
info@romi.es

ROMI in Mexico
Moliere 13, piso 10-B
Col. Chapultepec Polanco,
C.P. 11560
ventasmx@romi.com

ROMI Italia Srl
Via Morigi, 33 - 29020
Gossolengo, Piacenza - Italy
Phone +39 349 590 0474
macchineutensili@romi.com



CE safety regulation compliance available only for the European Community or under request.

ISO 9001:2008
Certificate No. 31120

ISO 14001:2004
Certificate No. 70671

ROMI C SERIES / IN / AL-01 / 09/2015 - Illustrative photos - Specifications are subject to change without prior notice - Please recycle.